



INDICATIVE PHOTO

## General features : SFL012G011

- Self-supporting casing in zinc-plated metal sheet, which is coated with epoxy powder and easily removable panels for fast access to components during inspection or maintenance operations
- Hermetic compressors with thermal motor protection
- Heat exchangers with copper and aluminium blocks
- Capillary expansion up to the model 54
- Condensation by air (optional by water)
- Automatic defrosting with programmable run, duration and frequency settings
- Electronic board that can be programmed according to different user requirements
- Control panel installed in a remote position
- Electronic control panel
- High pressure switch
- Remote control panel (5m)
- Door micro switch with 2,5m long cable
- Cold room light with 2,5m long cable
- Evaporating water tray
- Door heater cable for LBP items with 2,5m long cable
- Power supply cable (L=2,5m)
- Mounting set and overflow tube
- Package included



Indicative photo

## Product file : Refrigerating systems

Code	SFL012G011
Type	Compact
Mounting	Ceiling
Range	SF
Version	-
Expansion	Valve
Application	LBP
Gas	R452a
Net weight	105,5 kg
Ped	0
Defrost	Hot gas

## Compressor

Type	Hermetic
Voltage	220-240/1/50
Displacement	34,37cm <sup>3</sup>

## Pipe fittings

Liquid diam.	-
Suction diam.	-

## Absorptions

Power consumption	1203 W
Current consumption	6,3 A

## Condenser

Fans no.	2
Diameter	300 mm
Air flow	2500 m <sup>3</sup> /h

## Unit cooler

Fans no.	3
Diameter	200 mm
Air flow	1480 m <sup>3</sup> /h
Air throw	4 m

## Technical drawing - SFL012G011

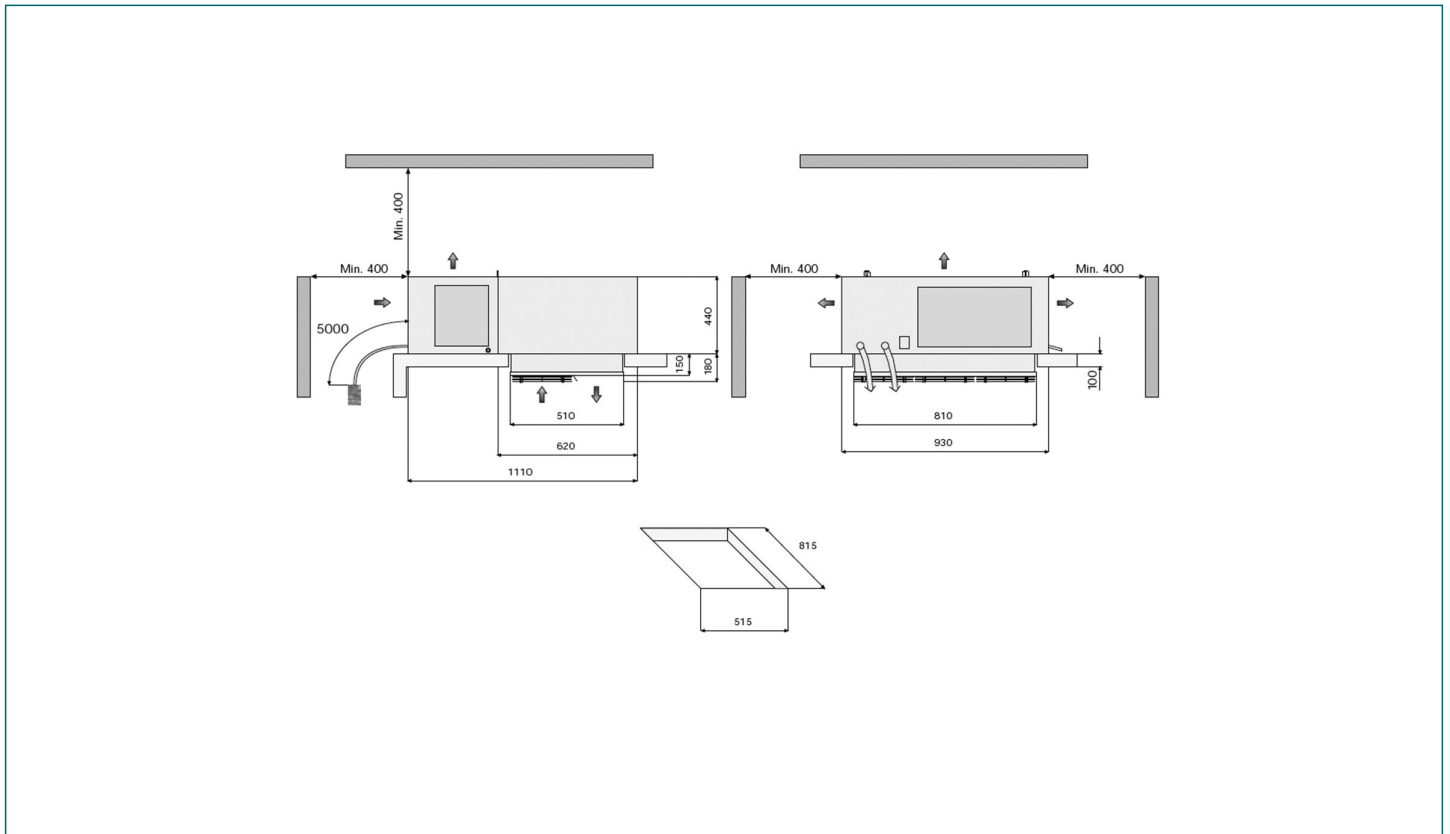

## Refrigerating capacity table (watt) - Gas : R452a

Ta \ Tc	-25°C	-20°C	-15°C
25°C	1294 (9,8 m³)	1596 (15 m³)	1923 (18,7 m³)
32°C	1155 (8,3 m³)	1429 (15,5 m³)	1725 (16 m³)
43°C	925 (5,2 m³)	1159 (7,4 m³)	1407 (10,9 m³)

### Values referred to :

- Suction gas : +20°C
- Subcooling : 0K
- Superheat : 100%
- Compressor absorption :
  - Te -5°C (HBP); Tcond +50°C
  - Te -10°C (MBP); Tcond +50°C
  - Te -30°C (LBP); Tcond +50°C